

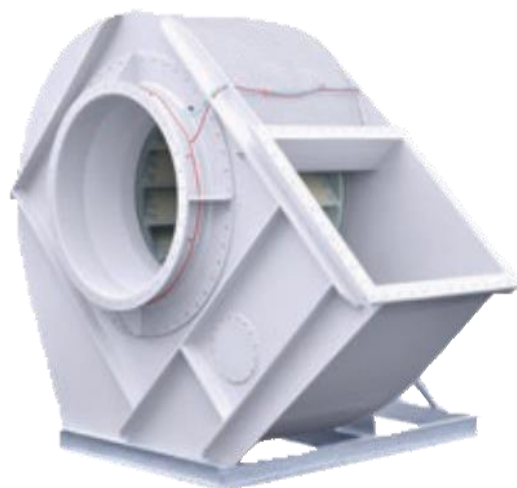

**OPERATION AND ASSEMBLY MANUAL  
OF CENTRIFUGAL FANS TYPE:**

Type	Size
HF R ...-15 / 17 D / R	125 - 500
HF R ...-13 D / R	450 - 1250
HF R ...-16 R	160 - 400
HF R ...-48 R	50 - 200



## Contents

1	INTRODUCTION .....	3
2	CONSTRUCTION AND CORRECT USE FOR THE INTENDED APPLICATION .....	3
2.1	CONSTRUCTION OF THE FAN.....	3
2.2	CORRECT USE FOR THE INTENDED APPLICATION AND FIELD OF APPLICATION.....	7
3	PRODUCT SPECIFIC DATA .....	8
3.1	GENERAL DATA.....	10
3.2	POWER SUPPLY (see motor type label).....	10
4	SAFETY.....	11
4.1	SIGNS AND EXPLANATIONS .....	11
4.2	FAN MARKING .....	12
4.3	BULIT-IN SAFETY SYSTEMS (to be implemented by the user) .....	12
4.4	INTERFANCES OF THE FAN .....	13
4.5	SAFETY MEASURES (to be implemented by the user) .....	13
4.6	USER'S RESPONSIBILITIES .....	13
5	GENERAL WARNING SYMBOLS.....	14
5.1	HAZARDS .....	14
5.2	OPERATING AND HAZARDOUS AREAS ON THE FAN.....	14
5.3	INSTALLATION OF SPARE AND WEAR PARTS.....	14
6	INSTALLATION .....	15
6.1	SCOPE OF SUPPLIES.....	15
6.2	TRANSPORT AND PACKING.....	15
6.3	DELIVERY (also with spare and substitute parts).....	15
6.4	INTERMEDIATE STORAGE .....	15
6.5	TRANSPORT TO THE PLACE OF INSTALLATION (at the custome's site) .....	16
6.6	INSTALLATION, MOUNTING, INITIAL COMMISSIONING.....	16
6.7	OPERATING MODES.....	18
7	OPERATION .....	18
8	MAINTENANCE / CLEANING .....	18
8.1	CLEANING .....	19
8.2	LUBRICATION.....	19
8.3	TENSIONING OF V-BELTS .....	21
8.4	INSPECTION INTERVAL / FUNCTION CHECKING .....	23
8.5	VIBRATIONS.....	23
8.6	TIGHTENING TORQUES FOR BOLT CONNETCIIONS .....	23
8.7	GENERAL HINTS FOR MAINTENANCE .....	24
8.8	CHECKS .....	24
9	TROUBLES / CAUSES / MEASURES.....	25
10	EMERGENCY .....	26
11	DISMANTLING / DISPOSAL .....	26
	NOTES .....	27

## 1 INTRODUCTION

**These operating instructions are valid for the standard and ATEX versions.**

These operating instructions are part of the fan and must be available to the operating personnel at all times. The safety information given in these instructions must be followed. In the event of a fan resale, these operating instructions must be included with the equipment supplied.

In the event of supply or subsequent sale into the countries of the EEA, the operating instructions must be translated into the language of the user country accordingly. If the translated text contains divergences, always refer to the wording of the original (German) operating instructions, or contact the manufacturer.



### After receiving the device - check

- whether the device is in compliance with order,
- whether the data on the rating plate are the same as desired.
- whether fan was not damaged during transport (e.g. there are no dents/cracks)
- whether a motor documentation (containing manual) is attached

**In case of any irregularities, contact with your dealer or Venture Industries Sp. z o.o. service.**

## 2 CONSTRUCTION AND CORRECT USE FOR THE INTENDED APPLICATION

### 2.1 CONSTRUCTION OF THE FAN

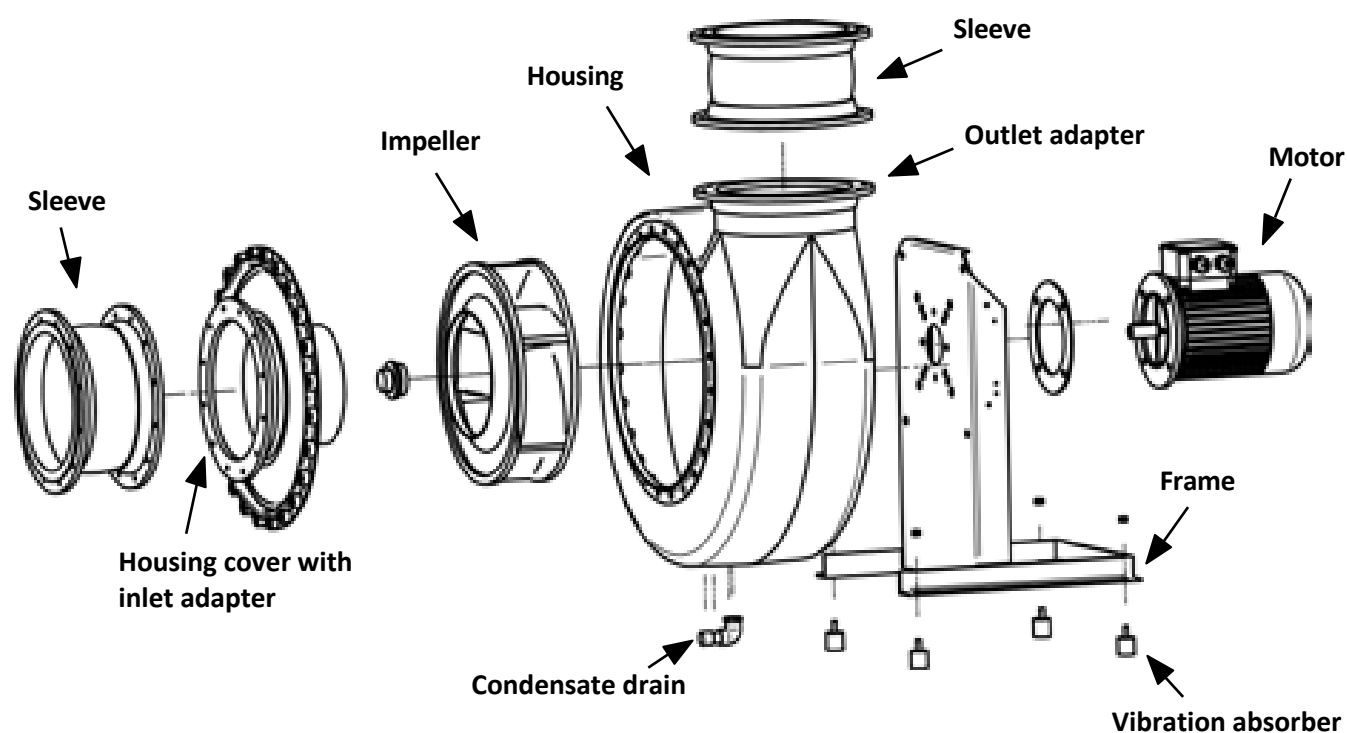

Fig. 1a | Overview of the fan HF R ...-15 / 17 D | Direct drive

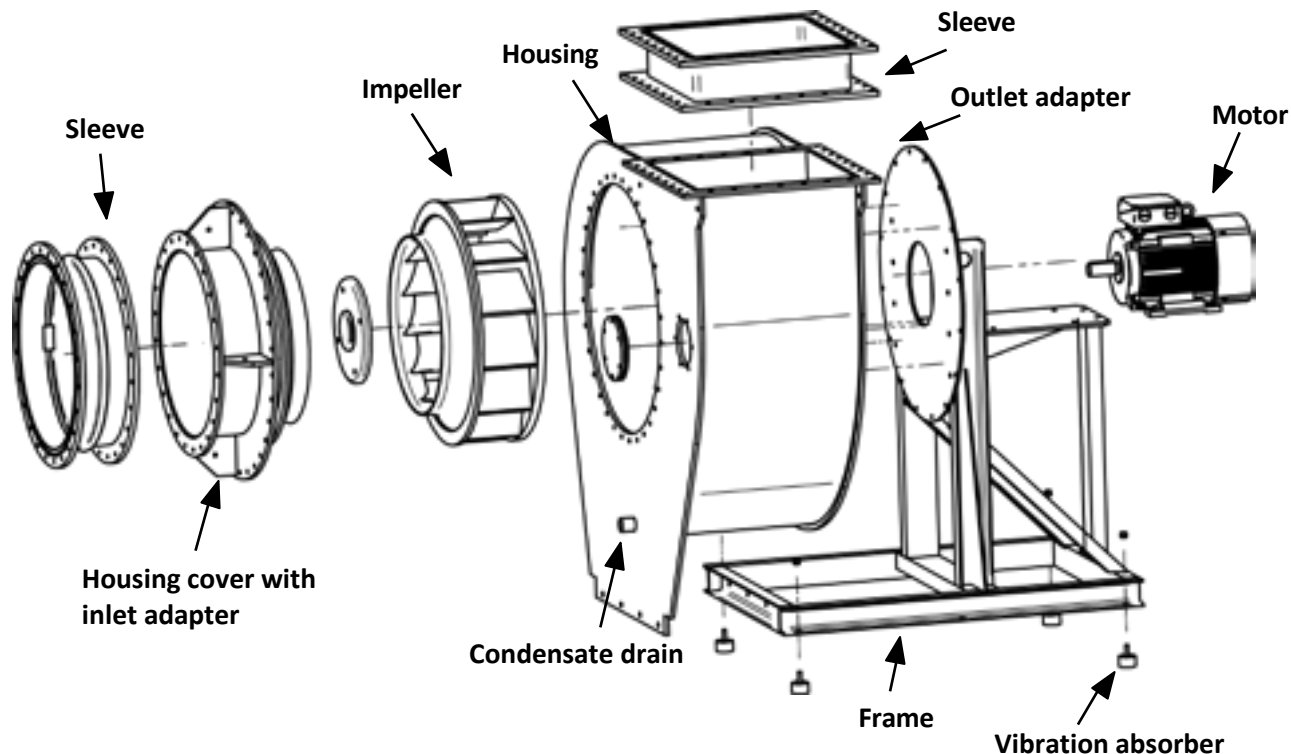

Fig. 1b | Overview of the fan HF R ...- 16 / 13 D | Direct drive

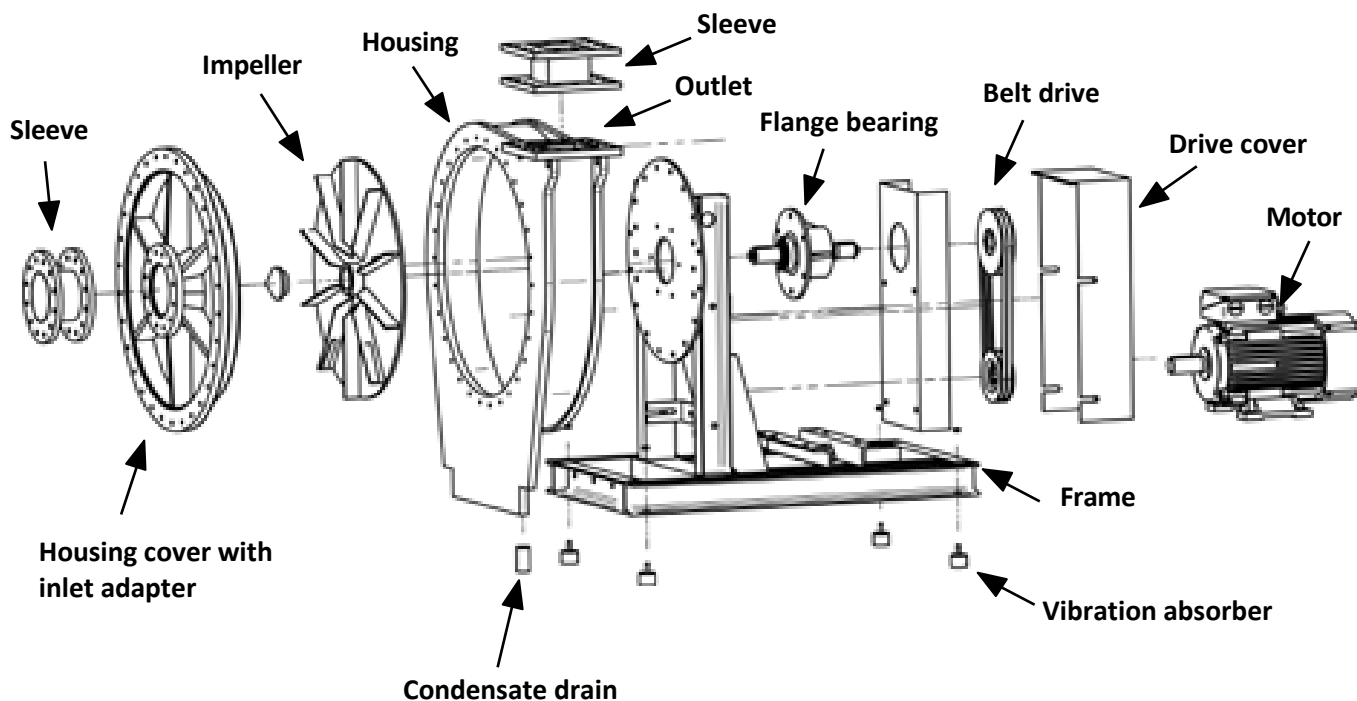
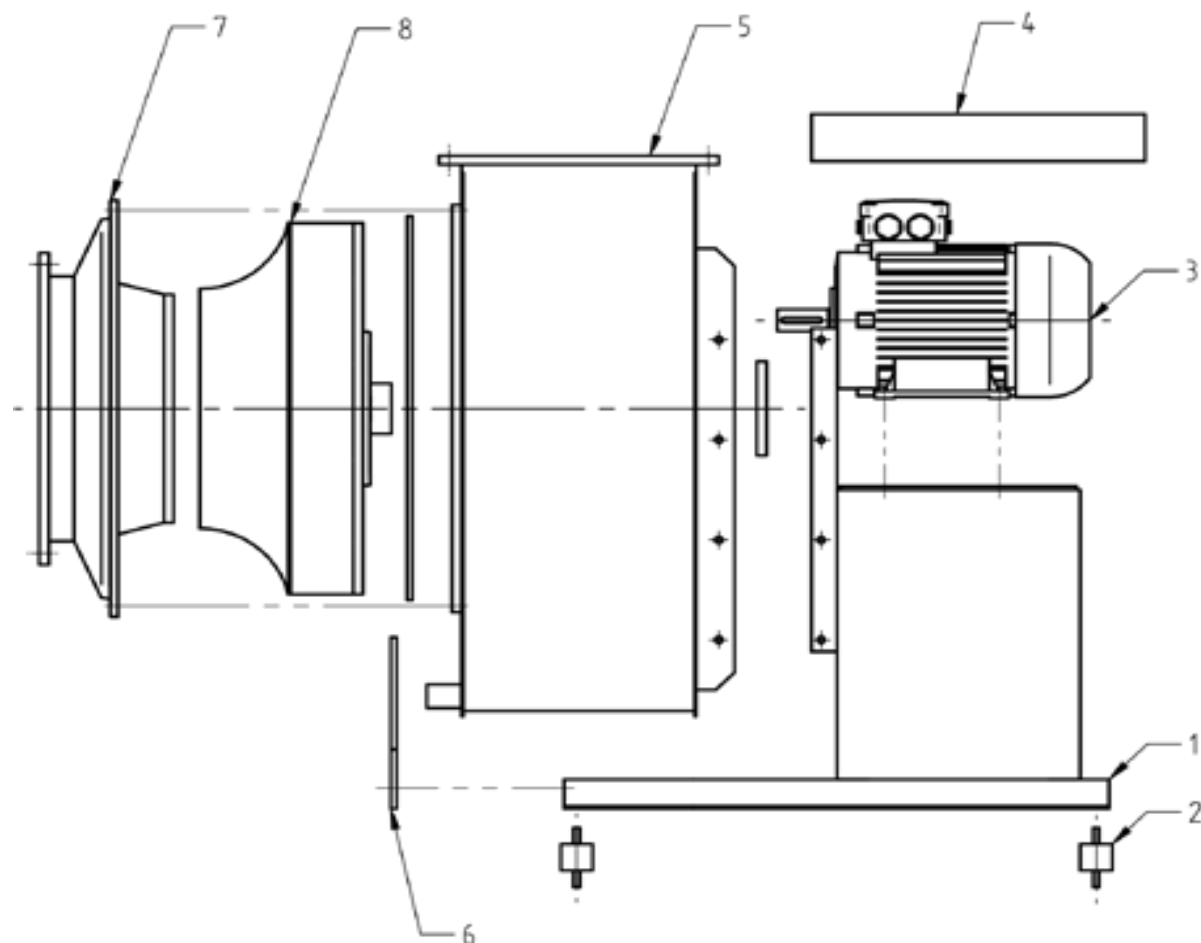
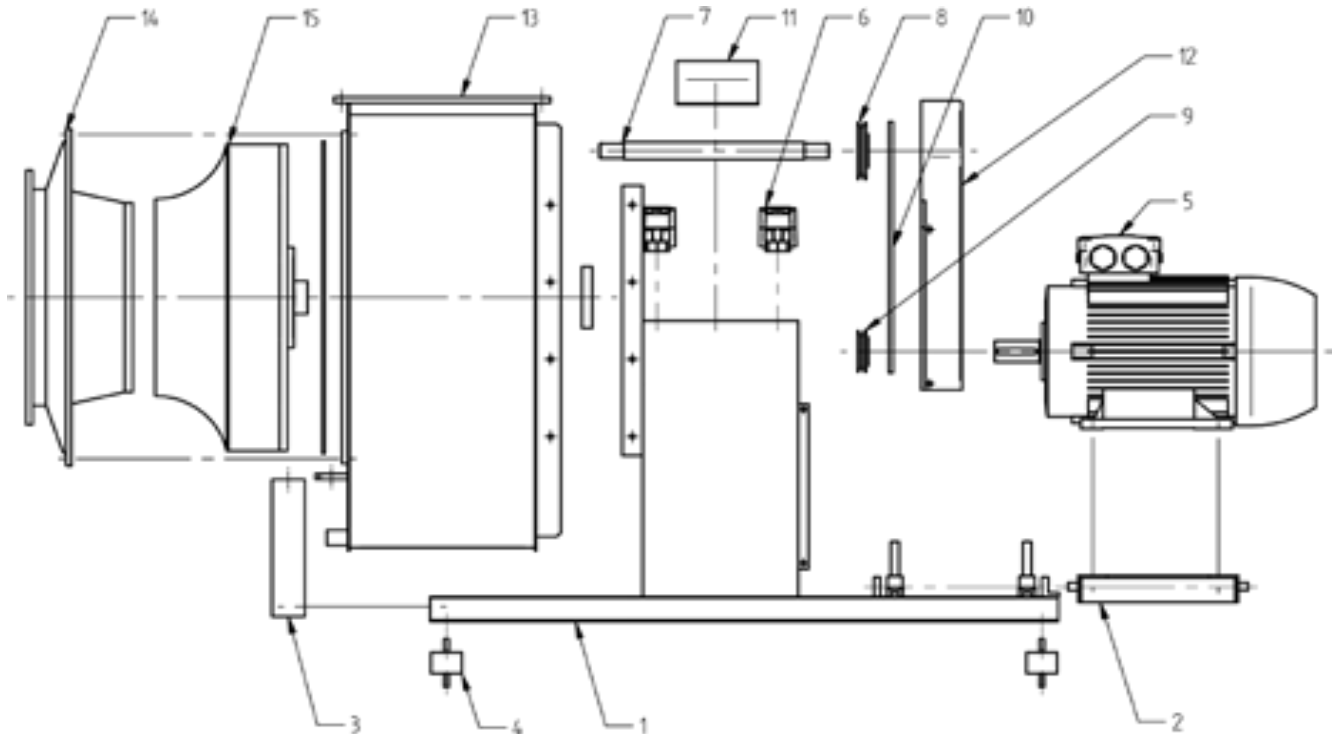

Fig. 1c | Overview of the fan HF R ...-48 R | Belt drive



Designation		Designation	
1	Frame	5	Housing
2	Vibration dampers	6	Support
3	Motor	7	Housing cover with inlet adapter
4	Motor cover (opt.)	8	Impeller

Fig. 1d | Overview of the fan HF R | Direct drive



Designation		Designation	
1	Frame	9	Belt pulley, Motor
2	Motor-clamp	10	V-Belt
3	Support	11	Shaft cover
4	Vibration dampers	12	Driver cover
5	Motor	13	Housing
6	Bearing	14	Housing cover with inlet adapter
7	Shaft	15	Impeller
8	Belt pulley, Fan		

Fig. 1e | Overview of the fan HF R | Belt drive

Centrifugal fans consist of the following main assemblies: Frame, housing, impeller and drive motor. They are delivered with direct drive (impeller on motor shaft) (except for the type HF R ...-48 R), as well as with belt drive (transmission motor-belt-impeller shaft).

The housings of the series HF R ...-15 / 17 D R are sintered with polyethylene (PEs. RAL7036) as standard. The housings of the other series are manufactured in self-supporting welded construction with different thermoplastics adapted to the particular conditions of use. They have a housing cap on the inlet side, which allows the mounting / dismantling of the impeller after demounting.

The housing is performed with a splinter protection, has on its deepest point (lateral) condensate drain drillings and it can be delivered with revision opening if requested.

The impeller is statically and dynamically balanced (min. quality class G 6.3 acc. to DIN ISO 21940-11). The vibration limits correspond to the ISO 14694 standard. Depending on the speed and other procedural parameters, various special materials are used as impeller materials in addition to thermoplastic. Main differentiating factor of these series are the different bladings of the impellers and the housing construction. On the type label are registered the maximum impeller r.p.m.s. For increasing the impeller r.p.m., previous consultation of the manufacturer or his representative is indispensable.

For fans which are appropriated for the use in Ex-zone 1 the housing and the impeller are made of electrical conductive thermoplastics. The standard thermoplastic plastic fan is not equipped with shaft sealing. The HF R ...- 13 D / R DS2 / DS3 series has a Kera seal as standard grown.

The exhaust fluid is aspirated axially by the rotating impeller and transported radially to the outlet in the helicoidal housing. The applied energy is converted into mass flow and pressure increase of the exhaust fluid in the impeller.

## 2.2 CORRECT USE FOR THE INTENDED APPLICATION AND FIELD OF APPLICATION

The fans are suitable for exhausting aggressive, dust-free, low-aerosol gases and clean air. Explosive atmosphere can be exhausted only using fans designed specially for this application. The permissible gas temperatures for the most frequently used plastics materials are generally:

- with PVC: 0 °C bis 50 °C,
- with PE, PE-FR (PEs) -20 °C to 60 °C,**
- with PP, PP-FR (PPs): 0 °C to 70 °C,**
- and with PVDF: -10 °C to 100 °C.

These temperatures must not be exceeded.

Depending on gas composition and impeller speed, these temperature ranges must be check and restricted, if necessary. With particularly aggressive media, the reductions must be checked and determined individually in each case. The max. ambient temperature is 40 °C. Sufficient cooling can be ensured regardless of the volume flow, in accordance with the above-mentioned conditions.

The fan was developed, designed and built exclusively for industrial and commercial use. Using the fan for domestic purposes is excluded.



### Installation inside the explosion-hazarded area:

Installation inside the explosion-hazarded area is not permissible, unless the fan is provided explicitly for this purpose (see type label Chapter 4.2).

If the fan for an installation with an open inlet or outlet or is provided for an inlet-side duct connection as part of a larger installation, the operator is obligated to prevent the penetration of foreign bodies that can cause ignition according to DIN EN 14 986, point 4.22.



### Repair and maintenance works of explosion-proof fans may **only** be performed by **qualified persons in the explosion protection** by using **original spare parts**.

If the fan has an open inlet and / or outlet (Type A, B, C according to ISO 13349), the fan must have the same category inside and outside.

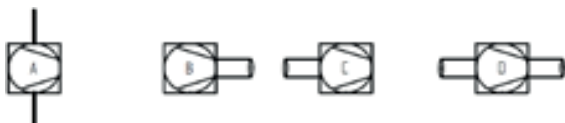

Types of connection



### Residual risks

Although the fans have been constructed according to the newest technology as well as to the security rules and they are monitored by quality assurance (QA) system, there remains a residual risk due to the possible rupture of the impeller. This happens especially, when the conditions of use have not been complied. Therefore it is necessary to pay attention on technically perfect conditions and on the right case of application. The environment of the fans has to be secured in such a way, that in case of a damage, neither persons nor objects get harmed.



These assemblies are intended exclusively for the above purpose. Using the assemblies for different purposes than described above, or modifying them without written consent of the manufacturer are considered as non-compliant with the intended application. The manufacturer cannot be held responsible for damage resulting from such use. The risk is borne exclusively by the user. The fan may be started only after checking that all safety devices are operable and that the system in which this fan is installed complies with the EU directives.

The correct use for the intended application also implies compliance with the instructions given in the manufacturer operating manual and with the conditions for maintenance and repair.

The plastic fans are not covered by the „Regulation No 327/2011 of the European Commission about the implementation of Directive 2009/125/EC (ErP Directive)“ because they are intended for the extraction of highly corrosive media.

### 3 PRODUCT SPECIFIC DATA



The materials/fluids for the correct use of the fan in compliance with the intended application are procured and applied by the manufacturer. The user is responsible exclusively for correct handling of these materials/fluids and the related hazards. Information on hazards and disposal must be provided by the user. Follow the rules given in the manufacturer's safety data sheets for materials and fluids.

#### Technical data sheet

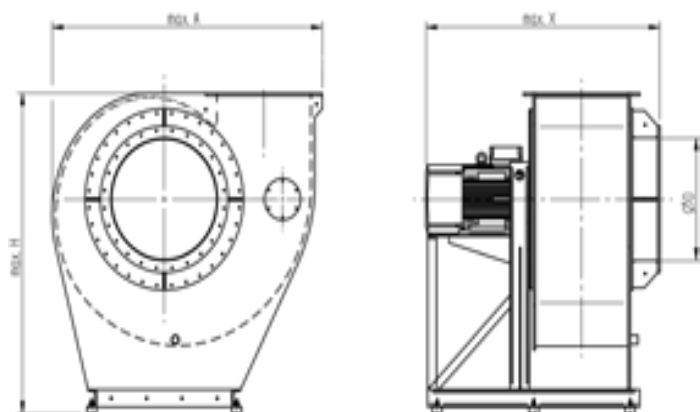

Fig. 2a | Overview of the fan HF R | Direct drive

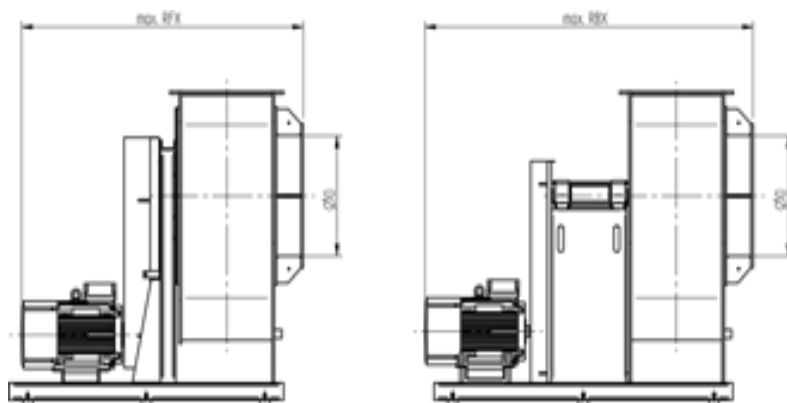

Fig. 2b | Overview of the fan HF R | Belt drive:  
Belt flange bearing (RF) and Belt block bearing (RB)



Type	ØD	max. A	max. H	max. X	max. kg.	max. RFX	max. kg
HF R 125-15/17	125	366,5	435	504	12		
HF R 140-15/17	140	409	462	518	13		
HF R 160-15/17	160	464	861,5	725	91	880	99
HF R 180-15/17	180	522	558	629	27	760	28
HF R 200-15/17	200	582	945	812	110	1037	166
HF R 250-15/17	250	732	1040	925	129	1080	174
HF R 280-15/17	280	816	804	768	62	923	56
HF R 315-15/17	315	920,5	1290	1179	260	1334	351
HF R 355-15/17	355	1030	1426	1151	214	1412	352
HF R 400-15/17	400	1141	1562	1255	280	1451	402
HF R 450-15/17	450	1297	1625	1320	310	1546	552
HF R 500-15/17	500	1469	1811	1378	506	1575	691

Type	ØD	max. A	max. H	max. X	max. kg.	max. RFX	max. kg	max. RBX	max. kg
HF R 450-13	450	1200	1250			1550		1950	
HF R 500-13	500	1350	1400			1650		2050	
HF R 560-13	560	1575	1860	1471	600	1836	650	2110	750
HF R 630-13	630	1770	2065	1635	950	1965	1000	2155	800
HF R 710-13	710	1985	2310	1710	1150	2040	1200	2405	1200
HF R 800-13	800	2235	2470	1889	1350	2249	1450	2700	1500
HF R 900-13	900	2515	2750	2223	1850	2583	1950	2895	2000
HF R 1000-13	1000	2780	3060	2343	2596	2813	2200	3220	2300
HF R 1120-13	1120	2942	3500	2621	3298	3106	2350	3410	3500
HF R 1250-13	1250	3105	3840	2900	4000	3400	4300	3600	4700

Type	ØD	max. A	max. H	max. RFX	max. kg
HF R 160-16	160	459	750	850	33
HF R 200-16	200	582	730	1020	41
HF R 250-16	250	710	775	1150	58
HF R 315-16	315	893	965	1350	81
HF R 355-16	355	1008	1090	1450	98
HF R 400-16	400	1126	1250	1450	149

Type	ØD	max. A	max. H	max. RFX	max. kg
HF R 50-48	50	372	605	622	85
HF R 63-48	63	455	640	633	100
HF R 80-48	80	566	705	719	150
HF R 100-48	100	703	805	781	200
HF R 125-48	125	860	950	929	300
HF R 160-48	160	1100	1180	1021	400
HF R 200-48	200	1353	1390	1215	550

Dimensions and design can be changed | Dimensions in mm

### 3.1 GENERAL DATA

#### Ambient temperature range

The specifications on the type label are applicable. If they are missing, the temperature range is - 20 °C to + 40 °C.

#### Noise level

For the value applicable to each fan, see the manufacturer/representative internet site, or contact us via phone.

#### Others

More relevant data are given on the type label.

The service life of bearing is depending on the load at > 25 000 h.

### 3.2 POWER SUPPLY (see motor type label)

Optionally, the electric motors can be controlled continuously by means of a frequency inverter.

The maximal rotation speed at the impeller (see fan type label) must not be exceeded.

The ICA (instrumentation technology, control technology, automation technology) on site must ensure protection against overspeed in compliance with EN 60204-1 and compliance with the technical standard against electrical erosion. The instructions of the frequency-converter and motor manufacturers must be observed.

Motor bearing damage caused by inadequate measures during operation on frequency inverters does not constitute cause for complaint.

We explicitly state that, if the bearing damage is demonstrably caused by bearing currents, HLU or the motor manufacturer is not at fault. A bearing that has failed due to bearing currents is not a fault that is due to a manufacturer's error (production error).

In case of operation of several motors with a frequency inverter all-pole sinusoidal filters should be used between frequency inverter and motor.

If frequency inverters are used in the explosion-hazarded area (Zone 1) these must be installed outside the explosion-hazarded area and flameproof motors to DIN EN 60079-1 must be used.



Before connecting the fan, check the specifications on the type label and dimension the electrical control system accordingly.

With a motor power  $\geq 4$  kW for starting up the fan is a star-delta-connection, a soft starter or a FI regulation to use to protect the impeller and the motor bearing against premature damages.



In the case of direct involvement or frequent restart, damage or increased wear may arise by the torque forces on the impeller.

## 4 SAFETY

### 4.1 SIGNS AND EXPLANATIONS



**The information given in the operating manual is binding**  
is marked with a „book“.



**Warnings**  
are marked with a „STOP“ sign.



**Danger warnings**  
are marked with a warning triangle.



**Notes**  
are marked with a hand symbol.



**Hazards due to electric current**  
are marked with the symbol shown opposite.



**Protective earth connection**  
is marked by these symbols at the connecting points.



**Hazards due to explosive atmosphere**  
are marked with the symbol shown opposite.

### 4.2 FAN MARKING

<p style="font-size: 8px; margin: 0;">www.venture.pl www.ventur.se www.ventur.fi www.venturdeutschland.de</p> <p style="font-weight: bold; font-size: 12px; margin: 0;">VENTUR</p> <p style="font-size: 8px; margin: 0;">VENTUR TEKNISKA AB VENTUR FINLAND OY VENTUR DEUTSCHLAND GmbH</p> <p style="font-size: 8px; margin: 0;">Manufacturer: VENTURE INDUSTRIES SP. Z O.O.</p>	<p style="font-size: 8px; margin: 0;">www.venture.pl www.ventur.se www.ventur.fi www.venturdeutschland.de</p> <p style="font-weight: bold; font-size: 12px; margin: 0;">VENTUR</p> <p style="font-size: 8px; margin: 0;">VENTUR TEKNISKA AB VENTUR FINLAND OY VENTUR DEUTSCHLAND GmbH</p> <p style="font-size: 8px; margin: 0;">Manufacturer: VENTURE INDUSTRIES SP. Z O.O.</p>																																																																								
<table border="1" style="width: 100%; border-collapse: collapse;"> <tr> <td>Type</td> <td>HFR-4-560-13</td> <td>Serial No.</td> <td>0002</td> <td>Date</td> <td>03.2024</td> </tr> <tr> <td>Pos.</td> <td></td> <td>Order No.</td> <td>P1124670-2-1</td> <td>Casing material</td> <td>PPs-el</td> </tr> <tr> <td></td> <td></td> <td>Fan ref. No.</td> <td>434015354-01</td> <td>Impeller material</td> <td>PPs-el</td> </tr> </table>	Type	HFR-4-560-13	Serial No.	0002	Date	03.2024	Pos.		Order No.	P1124670-2-1	Casing material	PPs-el			Fan ref. No.	434015354-01	Impeller material	PPs-el	<p style="font-weight: bold; font-size: 12px;">II 2G Ex h IIB+H2 T4 Gb</p>																																																						
Type	HFR-4-560-13	Serial No.	0002	Date	03.2024																																																																				
Pos.		Order No.	P1124670-2-1	Casing material	PPs-el																																																																				
		Fan ref. No.	434015354-01	Impeller material	PPs-el																																																																				
<table border="1" style="width: 100%; border-collapse: collapse;"> <tr> <td></td> <td style="text-align: center;">Stage 1</td> <td style="text-align: center;">Stage 2</td> <td></td> </tr> <tr> <td>Airflow</td> <td style="text-align: center;">m<sup>3</sup>/h</td> <td style="text-align: center;">3920</td> <td rowspan="5" style="text-align: center; vertical-align: middle;">                 Has its own rating plate for ATEX 2014/34/UE             </td> </tr> <tr> <td>Static pressure</td> <td style="text-align: center;">Pa</td> <td style="text-align: center;">1330</td> </tr> <tr> <td>Speed</td> <td style="text-align: center;">min<sup>-1</sup></td> <td style="text-align: center;">1450</td> </tr> <tr> <td>Configuration power</td> <td style="text-align: center;">kW</td> <td style="text-align: center;">3,0</td> </tr> <tr> <td>Operating temp.</td> <td style="text-align: center;">°C</td> <td style="text-align: center;">20</td> </tr> <tr> <td>Max. rpm at 60°C</td> <td style="text-align: center;">min<sup>-1</sup></td> <td style="text-align: center;">1450</td> <td></td> </tr> <tr> <td>Supply voltage</td> <td colspan="2" style="text-align: center;">3x400V 50Hz</td> <td></td> </tr> <tr> <td colspan="2" style="text-align: center;">0°C ≤ Operating temp. ≤ 40°C</td> <td colspan="2"></td> </tr> <tr> <td colspan="2" style="text-align: center;">-20°C ≤ ambient temperature ≤ 40°C</td> <td colspan="2"></td> </tr> </table>		Stage 1	Stage 2		Airflow	m <sup>3</sup> /h	3920	Has its own rating plate for ATEX 2014/34/UE	Static pressure	Pa	1330	Speed	min <sup>-1</sup>	1450	Configuration power	kW	3,0	Operating temp.	°C	20	Max. rpm at 60°C	min <sup>-1</sup>	1450		Supply voltage	3x400V 50Hz			0°C ≤ Operating temp. ≤ 40°C				-20°C ≤ ambient temperature ≤ 40°C				<table border="1" style="width: 100%; border-collapse: collapse;"> <tr> <td>Type</td> <td>HFR-4-560-13</td> <td>Serial No.</td> <td>0002</td> <td>Date</td> <td>03.2024</td> </tr> <tr> <td>Pos.</td> <td></td> <td>Order No.</td> <td>P1124670-2-1</td> <td>Casing material</td> <td>PPs-el</td> </tr> <tr> <td></td> <td></td> <td>Fan ref. No.</td> <td>434015354-01</td> <td>Impeller material</td> <td>PPs-el</td> </tr> </table>	Type	HFR-4-560-13	Serial No.	0002	Date	03.2024	Pos.		Order No.	P1124670-2-1	Casing material	PPs-el			Fan ref. No.	434015354-01	Impeller material	PPs-el																		
	Stage 1	Stage 2																																																																							
Airflow	m <sup>3</sup> /h	3920	Has its own rating plate for ATEX 2014/34/UE																																																																						
Static pressure	Pa	1330																																																																							
Speed	min <sup>-1</sup>	1450																																																																							
Configuration power	kW	3,0																																																																							
Operating temp.	°C	20																																																																							
Max. rpm at 60°C	min <sup>-1</sup>	1450																																																																							
Supply voltage	3x400V 50Hz																																																																								
0°C ≤ Operating temp. ≤ 40°C																																																																									
-20°C ≤ ambient temperature ≤ 40°C																																																																									
Type	HFR-4-560-13	Serial No.	0002	Date	03.2024																																																																				
Pos.		Order No.	P1124670-2-1	Casing material	PPs-el																																																																				
		Fan ref. No.	434015354-01	Impeller material	PPs-el																																																																				
<table border="1" style="width: 100%; border-collapse: collapse;"> <tr> <td></td> <td style="text-align: center;">Stage 1</td> <td style="text-align: center;">Stage 2</td> <td></td> </tr> <tr> <td>Airflow</td> <td style="text-align: center;">m<sup>3</sup>/h</td> <td style="text-align: center;">3920</td> <td rowspan="5" style="text-align: center; vertical-align: middle;">                 Has its own rating plate for ATEX 2014/34/UE             </td> </tr> <tr> <td>Static pressure</td> <td style="text-align: center;">Pa</td> <td style="text-align: center;">1330</td> </tr> <tr> <td>Speed</td> <td style="text-align: center;">min<sup>-1</sup></td> <td style="text-align: center;">1450</td> </tr> <tr> <td>Configuration power</td> <td style="text-align: center;">kW</td> <td style="text-align: center;">3,0</td> </tr> <tr> <td>Operating temp.</td> <td style="text-align: center;">°C</td> <td style="text-align: center;">20</td> </tr> <tr> <td>Max. rpm at 60°C</td> <td style="text-align: center;">min<sup>-1</sup></td> <td style="text-align: center;">1450</td> <td></td> </tr> <tr> <td>Supply voltage</td> <td colspan="2" style="text-align: center;">3x400V 50Hz</td> <td></td> </tr> <tr> <td colspan="2" style="text-align: center;">0°C ≤ Operating temp. ≤ 40°C</td> <td colspan="2"></td> </tr> <tr> <td colspan="2" style="text-align: center;">-20°C ≤ ambient temperature ≤ 40°C</td> <td colspan="2"></td> </tr> </table>		Stage 1	Stage 2		Airflow	m <sup>3</sup> /h	3920	Has its own rating plate for ATEX 2014/34/UE	Static pressure	Pa	1330	Speed	min <sup>-1</sup>	1450	Configuration power	kW	3,0	Operating temp.	°C	20	Max. rpm at 60°C	min <sup>-1</sup>	1450		Supply voltage	3x400V 50Hz			0°C ≤ Operating temp. ≤ 40°C				-20°C ≤ ambient temperature ≤ 40°C				<table border="1" style="width: 100%; border-collapse: collapse;"> <tr> <td></td> <td style="text-align: center;">Stage 1</td> <td style="text-align: center;">Stage 2</td> <td></td> </tr> <tr> <td>Airflow</td> <td style="text-align: center;">m<sup>3</sup>/h</td> <td style="text-align: center;">3920</td> <td rowspan="5" style="text-align: center; vertical-align: middle;">                 Has its own rating plate for ATEX 2014/34/UE             </td> </tr> <tr> <td>Static pressure</td> <td style="text-align: center;">Pa</td> <td style="text-align: center;">1330</td> </tr> <tr> <td>Speed</td> <td style="text-align: center;">min<sup>-1</sup></td> <td style="text-align: center;">1450</td> </tr> <tr> <td>Configuration power</td> <td style="text-align: center;">kW</td> <td style="text-align: center;">3,0</td> </tr> <tr> <td>Operating temp.</td> <td style="text-align: center;">°C</td> <td style="text-align: center;">20</td> </tr> <tr> <td>Max. rpm at 60°C</td> <td style="text-align: center;">min<sup>-1</sup></td> <td style="text-align: center;">1450</td> <td></td> </tr> <tr> <td>Supply voltage</td> <td colspan="2" style="text-align: center;">3x400V 50Hz</td> <td></td> </tr> <tr> <td colspan="2" style="text-align: center;">0°C ≤ Operating temp. ≤ 40°C</td> <td colspan="2"></td> </tr> <tr> <td colspan="2" style="text-align: center;">-20°C ≤ ambient temperature ≤ 40°C</td> <td colspan="2"></td> </tr> </table>		Stage 1	Stage 2		Airflow	m <sup>3</sup> /h	3920	Has its own rating plate for ATEX 2014/34/UE	Static pressure	Pa	1330	Speed	min <sup>-1</sup>	1450	Configuration power	kW	3,0	Operating temp.	°C	20	Max. rpm at 60°C	min <sup>-1</sup>	1450		Supply voltage	3x400V 50Hz			0°C ≤ Operating temp. ≤ 40°C				-20°C ≤ ambient temperature ≤ 40°C			
	Stage 1	Stage 2																																																																							
Airflow	m <sup>3</sup> /h	3920	Has its own rating plate for ATEX 2014/34/UE																																																																						
Static pressure	Pa	1330																																																																							
Speed	min <sup>-1</sup>	1450																																																																							
Configuration power	kW	3,0																																																																							
Operating temp.	°C	20																																																																							
Max. rpm at 60°C	min <sup>-1</sup>	1450																																																																							
Supply voltage	3x400V 50Hz																																																																								
0°C ≤ Operating temp. ≤ 40°C																																																																									
-20°C ≤ ambient temperature ≤ 40°C																																																																									
	Stage 1	Stage 2																																																																							
Airflow	m <sup>3</sup> /h	3920	Has its own rating plate for ATEX 2014/34/UE																																																																						
Static pressure	Pa	1330																																																																							
Speed	min <sup>-1</sup>	1450																																																																							
Configuration power	kW	3,0																																																																							
Operating temp.	°C	20																																																																							
Max. rpm at 60°C	min <sup>-1</sup>	1450																																																																							
Supply voltage	3x400V 50Hz																																																																								
0°C ≤ Operating temp. ≤ 40°C																																																																									
-20°C ≤ ambient temperature ≤ 40°C																																																																									

Specifications for fans without explosion protection  
Fig. 3a | Type label (normal application)

Specifications for fans with explosion protection  
Fig. 3b | Type label (explosive atmosphere)



**Caution**

Fans without explosion protection marking are not permissible for operation inside the explosion-hazarded atmosphere. This applies to the environment and the exhausted fluid.

Meaning of possible device categories on the type label:	
II 2G	The fan is suitable for exhaustion from zone 1 and for installation in zone 1
II 2/3G	The fan is suitable for exhaustion from zone 1 and for installation in zone 2
II 3G	The fan is suitable for exhaustion from zone 2 and for installation in zone 2
II 3/-G	The fan is suitable for exhaustion from zone 2 and must be installed outside the hazardous area

The information given in these operating instructions is only applicable to the fan type specified on the title page. The type label with the type denomination is located on the base frame or on the side panel of the fan housing. With all enquiries, make sure to specify the order confirmation no. and the type label properly to ensure correct and quick handling.

### 4.3 BUILT-IN SAFETY SYSTEMS (to be implemented by the user)

The built-in safety devices must be checked at regular intervals:

**d** = daily, **w** = weekly, **m** = monthly, **y** = yearly.

The following methods must be used for checking:

**V** = visual check, **F** = functional check, **M** = measurement.

**Overcurrent protection device**

To prevent overheating (fire hazard) in the event of overload (e.g. due to clogging), the fan drive has to be provided with an overcurrent protection device.

Check	
Interval	Method
y	F

**Thermal contact (optional)**

For temperature monitoring, the fan is equipped with a thermal contact. In the event of a temperature increase, the motor switches off.

Check	
Interval	Method
y	F

**PTC resistor (optional)**

Don't connect the PTC resistor to the mains voltage. Avoid exceeding a max. PTC resistor test voltage of 2.5 V.

Check	
Interval	Method
y	F

**Protective claddings**

All mobile fan components driven by the electric motor as well as all other hazardous parts of the fan are covered by fixed, safely fastened protective claddings that can be removed only using tools.

Check	
Interval	Method
m	V

**Electrical connection**

The electrical connections are made using a 4-wire supply cable system, 3 phases and 1 earth conductor with three-phase motors and using a 3-wire supply cable system, 1 phase, 1 neutral wire and 1 earth conductor with alternating current motors.

Check	
Interval	Method
y	V, F, M



Deactivating the safety devices, or changing their operating principle, is strictly prohibited.

4.4 INTERFANCES OF THE FAN

The fan has the following interfaces:

- Outlet side (connection via sleeve with tightening strap or flange)
- Terminal box or maintenance switch (electric supply)
- Inlet side (connection via sleeve with tightening strap or flange)

4.5 SAFETY MEASURES (to be implemented by the user)

We point out that the user is under the duty to:

- instruct the operating and maintenance personnel on the protective devices of the fan,
- and to ensure supervision concerning compliance with the safety measures.

This operating manual must be kept for future use. The specified frequency of inspection and control measures must be met.

- The chapters related to transport, installation and mounting, maintenance, troubles/causes/ troubleshooting must be understood by a qualified person. Work described in this chapter may be performed only by **qualified personnel**.

4.6 USER'S RESPONSIBILITIES



In the European Economic Area, compliance with Council Directive (89/391/EEC) and the related individual directives, especially Council Directive 89/655/EEC Concerning the Minimum Safety and Health Requirements for the Use of Work Equipment by Workers at Work in the relevant national version is mandatory..

The user must obtain the local operating licence and follow the relevant rules.

Additionally, the user must ensure compliance with the national legal regulations concerning:

- the personnel safety (regulations relating to accident prevention)
- the safety of work equipment (protective equipment and maintenance)
- product recycling (Waste Management Law)
- material disposal (Waste Management Law)
- cleaning (cleaning agents and disposal)
- and comply with the requirements for environment protection.



To avoid the occurrence of ignition sources, the operating and maintenance personnel must be equipped properly and receive adequate instructions for realization of cleaning and maintenance work, e.g.:

- to avoid the use of tools giving rise to sparking,
- strict observance of the smoking ban,
- to avoid the actuation of ignition sources (e.g. lighters, etc.).

## 5 GENERAL WARNING SYMBOLS

### 5.1 HAZARDS

Pay attention to the safety devices described in this manual and follow the safety notes.



During setup, maintenance and repair work, mind the **squeezing hazards!**



During setup, maintenance and repair work, mind the **hazard due to electric current!**



During setup, maintenance and repair work, be aware of the **risk of getting burned** due to hot components. In the event of a failure of the forced ventilation, the drive motor presents a hazard of **getting burned**.



When doing setup, maintenance and repair work within the explosion-hazarded area, make sure that there isn't a critical gas concentration. Use a gas detector. Always avoid handling all kinds of ignition sources inside the explosion-hazarded area. Welding, cutting and polishing work may be performed only, if the related permission was granted.

### 5.2 OPERATING AND HAZARDOUS AREAS ON THE FAN

#### Hazardous area

During setup, maintenance and repair work, the overall area around the fan is a hazardous area.



During maintenance and repair work, the hazardous area extends 1 m around the fan. The flap pivoting area must be taken into account as well. Keep the area around the fan free from any objects.

### 5.3 INSTALLATION OF SPARE AND WEAR PARTS

We point out explicitly that spare parts and accessories not supplied by us are not checked and released for use by us either. Installation and/or use of these products can change the design properties of your fan negatively. The manufacturer cannot be held responsible for damage resulting from the use of other than original components. In connection with the order confirmation, you will receive a data card and a spare parts list for the fan.

When ordering spare parts, please provide the following information:

- Order number (see nameplate)
- Fan type
- Name of the spare part

## 6 INSTALLATION

### 6.1 SCOPE OF SUPPLIES

**The equipment delivered to the user comprises:**

- Centrifugal fan
- Operating manual
- Technical documents

For the detailed scope of equipment supplied, refer to the order confirmation.

### 6.2 TRANSPORT AND PACKING

Although the fans are checked and packed carefully before shipment, damage during transport cannot be excluded.

### 6.3 DELIVERY (also with spare and substitute parts)

**Inspection of incoming components:**

- Check, if the consignment is complete according to the bill of delivery.

**In the event of damage**

- Check the consignment for damage (visual inspection).

**In the event of complaints**

If the consignment was damaged during transport:

- Contact the last forwarder immediately.
- Keep the packaging (for checking by the forwarder or for returning the product).

**Packaging for returning the product**

- If possible, use the original packaging and the original packaging material. If the original packaging and packaging material haven't been kept, use commercial packaging material. Fasten the fan to a transport pallet (it must be dimensioned appropriately for the weight).
- With any questions relating to packaging and safe transport, please, consult the sales representative or manufacturer.

### 6.4 INTERMEDIATE STORAGE

The fans should be stored in a room or under a shelter. With outdoor storage, protect the fan from dirt and atmospheric conditions using a canvas cover. Keep the storage temperature between 0 °C and + 40 °C.

To avoid permanent deformation by preventing static load at the contact points between the rolling elements and bearing raceways, the impeller has to be turned for a ¼ turn at regular intervals (at least every 4 weeks).

With belt-driven fans, note that the V-belts must be released in case of prolonged storage periods or standstill (> 4 weeks), in order to prevent damage of bearings and V-belts.

## 6.5 TRANSPORT TO THE PLACE OF INSTALLATION (at the customer's site)



Transport must be performed only by qualified personnel in compliance with the local conditions and any warning notes on the packaging material.

The fan or fan unit is transported on transport pallets to the site.



The fan or transport unit **may tip** over during transport. Pay attention to the **focus** (the focus is centred) and **weight** (see technical data).

Secure the fan or the transport unit with appropriated resources before the transport.

### Transport with forklift

- The forklift has to be adjusted according to the weight of the fan or the transport unit.
- Drive with the forks of the forklift between or under the arbors of the transport pallet of the fan or the transport unit.
- Make sure that the forks of the forklift are completely under the arbor (the forks have to look out at the opposite).
- Lift the fan or transport unit and transport it.

Weight see cap. 3.

### Transport of the fan to the site



The fan has to be transported with appropriated resources at the designated points and it has to be secured against overturning.

**Attention: The focus must be on the bottom!**

The lifting and transporting of the fans can be done manually depending on the size and the weight.

Fig. 4| Transport of the fan to the site

## 6.6 INSTALLATION, MOUNTING, INITIAL COMMISSIONING

Installation, mounting and initial commissioning of the fan are performed by qualified personnel of manufacturer or by qualified customer personnel that must have been trained adequately for this work.

- The constructional arrangement of the fan must ensure that operational underpressure conditions are present at the shaft passage.
- Check on the basis of the static of the building, if it is adjustable for the burden of the fan and if the bottom is flat.
- The installation of the fans and their components are based on the on-site installation plan.  
The fan must be mounted on vibration dampers. The Vibration absorbers used for installation of the fan must be mounted by means of screws in the marked and readily drilled positions in the foundation frame and fastened with bolts in the on-site foundation. This is necessary to absorb occurring oscillations / vibrations and to prevent damage to the drive and fan.
- We recommend a circumferential distance of approx. 1.5 m to 2 m, for maintenance work at the fan.  
For maintenance work at the inlet side of the fan, the housing cover should be removed if necessary. Therefore we advise mounting a removable pipe section of approx. 1 m in front of the fan if the fan cannot be postpone.
- The fan must not be operated in non-installed condition. The impeller must be free to move without any impediment at all times.
- Mount the (on-site) pipe.



- The fan is equipped with a terminal box (or maintenance switch) for connecting to the mains supply. The motor enclosure must be closed using a sealing joint certified according to the EN IEC 60079-0 and EN IEC 60079-1 standards. Users will have to connect the cable terminals using one of the protection types specified in standard EN 60079-0. The Energy supply can be cut off using an onsite maintenance switch (if it is not already installed at the fan).
- Check before the first operation that the turning direction is correct (direction arrow on the fan housing) and that the max. speed is not exceeded (see nameplate).
- If there is danger of foreign parts falling into the fan or being aspirated, the connected pipe upstream and downstream of the fan must be provided with a protective grid (min. IP20 to EN 60529).
- The motors are designed for a maximum ambient temperature of 40 °C. Ventilation must not be impaired. The minimum distance between fan housing and adjacent objects must be ¼ of the diameter of the flared fan housing bezel.
- W If the fan shall be installed outdoor, we recommend a protection of the drive motor against water.
- The inside of the fan and of upstream and downstream channels and units must be kept free from foreign bodies.
- After a run-in period of 1 or 2 hours check the drive at regular intervals and re-tighten the belts, if necessary.
- The condensate drain at the bottommost point of the housing has to be connected.
- See point 3.2.
- Ensure that connected lines do not carry loads which lead to a distortion of the fan housing.



The fan may be connected to the supply voltage and switched on only, when the pipe (on the inlet and outlet side) has been connected completely.

Installation must be performed according to the connecting diagram in the motor operating instructions only by adequately trained and qualified personnel.

**The following conditions must be met:**

- Compliance with the national regulations relating to the public utilities.
- The supply voltage at the place of installation and the mains frequency must correspond to the values specified on the motor type label.
- The power supply cable must be protected against damage and dimensioned adequately for the power rating.
- Set the thermal overcurrent relay to the nominal current specified on the motor type label and follow the instructions given in the motor operating instructions. We reserve ourselves the right to cancel the motor warranty in the event of failure to comply with this protective measure.



Make sure that the **rotating direction** is correct. To check the rotating direction, switch on the motor shortly and compare the impeller rotating direction with the arrow marked on the housing. If the rotating direction is wrong, change the motor polarity in compliance with the safety regulations. After reaching the operating speed, measure the power consumption immediately and compare it to the motor current specified on the type label.



**24 h** after initial commissioning: Check the tightness of the housing and the quiet run of the fan and re-tighten the screws.



**Caution**

The fan pipe connections may be performed only using flexible couplings (compensators).

## 6.7 OPERATING MODES

The fan is switched on and off via an on-site operating unit provided by the user, or operated via an on-site supervisory system. It is designed for continuous operation.

## 7 OPERATION



The fan may be operated only by specialized personnel qualified and trained for operation.

## 8 MAINTENANCE / CLEANING



The chapter on „**Maintenance / Cleaning**“ is intended only for qualified personnel. Maintenance, cleaning and repair work may be performed only by qualified personnel.

### Qualified person

A person who is able to assess the work he/she is in charge of and aware of potential hazards due to his/her professional training, skills and experience as well as his/her knowledge of the relevant standards.

### Definition according to EN 60204-1.

To ensure smooth operation of the fan, cleaning and maintenance of the fan at regular intervals is required.

During operation, the fan is subject to vibration susceptible of releasing screwed and clamping connections. To prevent damage, check the fan for loosened connections at regular intervals (recommended interval with single-shift operation: 3 months).



For information on maintenance/cleaning of individual components purchased from other manufacturers (e.g. electric motor), refer to the corresponding manufacturer operating instructions.



When switching off the supply voltage because of cleaning, maintenance and repair work, measures to prevent the supply voltage from being switched on accidentally must be taken by the user (locking the main or maintenance switch using a padlock).



During maintenance and repair work, mind all rotating and mobile parts. **Risk of entanglement!** Tight clothing must be worn in the danger area.



During maintenance and repair work, mind the **squeezing hazards**.



When doing maintenance and repair work, mind the **hazards due to electric current!**



Cleaning, maintenance and repair work may be done only at non-explosive atmosphere.  
For reasons of safety, only tools made of non-sparking material may be used when doing this work.



The work intervals specified below are intended for single-shift operation (8 hours a day; 22 days a month; 12 months a year).

- |                          |   |
|--------------------------|---|
| <b>d</b> = daily         | <b>y</b> = yearly                         |
| <b>w</b> = weekly        | <b>R</b> = cleaning required when opening |
| <b>m</b> = monthly       | <b>LT</b> = lifetime                      |
| <b>½ y</b> = half-yearly | <b>MO</b> = manufacturer operating manual |

### 8.1 CLEANING



Don't use any sharp objects or tools for cleaning. Only objects that are explicitly provided for this purpose are suitable.

<b>Cleaning</b> (Depending to the degree of contamination the cleaning intervals must be adapted)	<b>Interval</b>
Keep the fan and the area around the fan free from deposits on the outside regularly (e.g. dust, exhaust fluids).	<b>w</b>
Check the impeller regularly for contaminations and cakings and clean it, if necessary. <b>Caution</b> Contaminations on the impeller can cause imbalance of the fan. Depending on the intensity, this can even cause the destruction of the fan.	<b>½ y</b>
Make sure that the cooling fins of the electric motor are not clogged by pollution in order to avoid overheating, if necessary clean them.	<b>m</b>



**Caution**

When doing cleaning work, wear protective equipment in compliance with the operational regulations for occupational health and safety (e.g. protective gloves).

### 8.2 LUBRICATION

The lubrication points of the fans have to be greased regularly using appropriated lubrication tools. The lubrication periods depend on the operating hours of the fan (see next schedule).

- The bearings of the installed maintenance-free electric motors have a grease filling, which is calculated for a service life of approx. 10.000 - 20.000 operating hours. The maintenancefree flange double bearings (299 T ...W, 399 T ...W), were filled with grease sufficiently by the manufacturers, this means they have a calculated service life of approx. 20000 operating hours.
- The periods and amount of the lubrication on the electric motor and regreasable double flange bearings 399T...N and block bearing 32T...ER depend on the operating hours of the fan. After max. 8000 operating hours at the latest after one year of operation the bearings have to be greased again according to the next schedule.
- We recommend as appropriated bearing grease a lithium soap grease, for example Shell-Alvania 2 or 3. The determined lubrication intervals are applicable to bearings in horizontal mounting position at a maximum temperature of 70 °C. As lubricant aging is accelerated at higher temperatures, the lubrication interval must be reduced by half with a temperaturę increase of 15 °C.
- Concerning the lubrication intervals of electric motors please note the operating and maintenance instructions of the engine producer.



Details about the kind, amount and period of lubrication of the single purchase component devices have to be taken from the external manufacturer's operating manual.

#### Greasing periods depending on the speed and nominal size of the fan:

##### HF R ...-15 / 17 D / R

Only the fan type HF R 250-17 R with a speed over 2000 min<sup>-1</sup> has got a regreasable bearing installed.

Nominal fan size	Speed fan				Quantity of greasing
	2000 min <sup>-1</sup>	2500 min <sup>-1</sup>	3000 min <sup>-1</sup>	3500 min <sup>-1</sup>	
HF R 250-17	8000 h	7000 h	5500 h	4500 h	8 g

##### HF R ...-13 D / R

Nominal fan size	Speed fan							Quantity of greasing
	500 min <sup>-1</sup>	750 min <sup>-1</sup>	1000 min <sup>-1</sup>	1500 min <sup>-1</sup>	2000 min <sup>-1</sup>	2500 min <sup>-1</sup>	3000 min <sup>-1</sup>	
HF R 450-13 RB			8000 h	8000 h	8000 h	6000 h	5000 h	10 g
HF R 500-13 RB			8000 h	8000 h	8000 h	6000 h		10 g
HF R 560-13 RB			8000 h	8000 h	7000 h	5000 h		15 g
HF R 630-13 RB			8000 h	8000 h	7000 h			15 g
HF R 710-13 RB		8000 h	8000 h	8000 h	7000 h			15 g
HF R 800-13 RB	8000 h	8000 h	8000 h	8000 h				20 g
HF R 900-13 RB	8000 h	8000 h	8000 h	8000 h				26 g
HF R 1000-13 RB	8000 h	8000 h	8000 h	7500 h				33 g
HF R 1120-13 RB	8000 h	8000 h	8000 h					33 g
HF R 1250-13 RB	8000 h	8000 h	8000 h					42 g

Nominal fan size	Speed fan						Quantity of greasing
	500 min <sup>-1</sup>	750 min <sup>-1</sup>	1000 min <sup>-1</sup>	1500 min <sup>-1</sup>	2000 min <sup>-1</sup>	2500 min <sup>-1</sup>	
HF R 450-13 RF			13000 h	10000 h	2000 h	1500 h	10 g
HF R 500-13 RF			13000 h	10000 h	7000 h	5000 h	13 g
HF R 560-13 RF			4000 h	2200 h	1500 h	1000 h	13 g
HF R 630-13 RF			4000 h	2200 h	7000 h	5000 h	21 g
HF R 710-13 RF			3800 h	2200 h	7000 h	4500 h	21 g
HF R 800-13 RF	17500 h	14000 h	10000 h	8000 h			21 g
HF R 900-13 RF	17500 h	14000 h	10000 h	8000 h			21 g
HF R 1000-13 RF	16000 h	13000 h	10000 h	8000 h			21 g

**HF R ...-16 R**

Nominal fan size	Speed fan											Quantity of greasing
	2000 min-1	2500 min-1	3000 min-1	3500 min-1	4000 min-1	4500 min-1	5000 min-1	5500 min-1	6000 min-1	6500 min-1	7000 min-1	
HFR160-16R	8000 h	8000 h	7000 h	6000 h	4800 h	4000 h	3500 h	3000 h	2750 h	2350 h	2000 h	5 g
HFR200-16R	8000 h	8000 h	7000 h	6000 h	4800 h	4000 h	3500 h	3000 h	2750 h			5 g
HFR250-16R	8000 h	7000 h	5500 h	4500 h	3200 h	2700 h	2000 h					7 g
HFR315-16R	7000 h	5000 h	4000 h	3000 h								9 g
HFR355-16R	7000 h	5000 h	4000 h	3000 h								9 g
HFR400-16R	7000 h	5000 h	4000 h	3000 h								9 g

**HF R ...-48 R**

Nominal fan size	Speed fan											Quantity of greasing
	2000 min-1	2500 min-1	3000 min-1	3500 min-1	4000 min-1	4500 min-1	5000 min-1	5500 min-1	6000 min-1	6500 min-1	7000 min-1	
HFR48-50	8000 h	8000 h	7000 h	6000 h	4800 h	4000 h	3500 h	3000 h	2750 h	2350 h	2000 h	5 g
HFR48-63	8000 h	8000 h	7000 h	6000 h	4800 h	4000 h	3500 h	3000 h	2750 h			5 g
HFR48-80	8000 h	7000 h	5500 h	4500 h	3200 h	2700 h	2000 h					7 g
HFR48-100	7000 h	5000 h	4000 h	3000 h								9 g
HFR48-125	7000 h	5000 h	4000 h									9 g
HFR48-160	6500 h	4500 h	3000 h									12 g
HFR48-200	6500 h											12 g

### 8.3 TENSIONING OF V-BELTS

**Pretension of V-belts**

Deflect a belt (the central belt with multiple-groove pulleys) at right angles to the free belt side by means of a spring balance. Measure the deflexion using a centimetre ruler. A required deflexion ( $E_a$ ) of 17 mm per 1000 mm of free belt side length was determined. The required deflexion is calculated by means of the following simplified equation:

$$E_a = \frac{17}{1000} * e$$

(e = Centre distance)

**Before work starting, note that:**

- Secure the fan against accidental start-up.
- Remove the belt cover.
- Measure the spring travel  $f = E_a$  at test force  $F$  using a traction balance.
- Increase or reduce the motor-to-bearing centre distance by adjusting the mounting screws until reaching the set-point. For this, release the locknut at the upper and lower setscrew. Shaft and belt pulleys must be exactly aligned, maximum deviation is  $1^\circ$ .

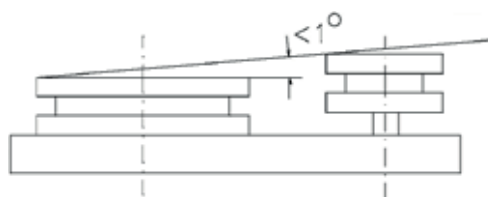

The values for test force depend on the profile and diameter of the little belt pulley (see next schedule).

Disc	Test load	Disc	Test load	Disc	Test load	Disc	Test load
SPA95	23	SPB150	42	SPC224	85	SPZ63	12
SPA100	25	SPB160	45	SPC236	88	SPZ67	13
SPA106	27	SPB170	48	SPC250	92	SPZ71	14
SPA112	29	SPB180	51	SPC265	96	SPZ75	15
SPA118	31	SPB190	54	SPC280	100	SPZ80	16
SPA125	33	SPB200	58	SPC300	106	SPZ85	17
SPA132	35	SPB212	61	SPC315	110	SPZ90	19
SPA140	36	SPB224	64	SPC335	115	SPZ95	20
SPA150	38	SPB236	66	SPC355	120	SPZ100	21
SPA160	39	SPB250	69	SPC375	123	SPZ112	22
SPA180	42	SPB280	77	SPC400	126	SPZ125	24
SPA180	45	SPB315	85	SPC425	130	SPZ140	25
				SPC450	134		
				SPC475	138		
				SPC500	141		
				SPC530	146		
				SPC560	150		

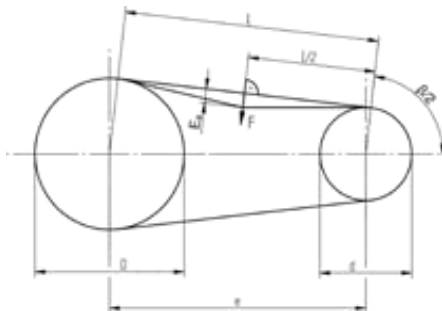

Designation	
e	Centre distance
β	Angle of belt contact
D	Diameter of big pulley
d	Diameter of little pulley
F	Test force in N
L	Free belt length
Ea	Required deflexion in mm

**Retension of V-belt**

(A bearing). Then pull the motor at the terminal box at a 45 ° angle downwards [F] so that the belt is tensioned. Tighten the screws slightly, then pull the motor downwards at an angle so that the belt tension rises again. While the tension is maintained, first tighten the screw with the clamping angle (1), then tighten the screw directly at the flange (2).

Then check the belt tension again and if necessary repeat the process until the required tension is reached (if sufficient force can not be applied, use torque-increasing measures [leverage]).

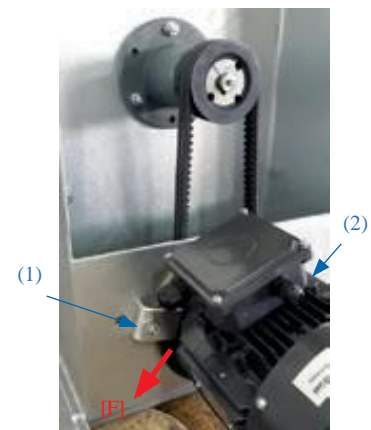

#### 8.4 INSPECTION INTERVAL / FUNCTION CHECKING

	Interval with single-shift operation					
	d	w	m	½ y	1 y	MO
Superordinate facility for connecting the supply voltage				x		
Settings of the on-site protective devices						x
Fan motor function checking						x
Bearing function checking						x
Check belt tension and correct if necessary				x		
Check the impeller for damage				x		

#### 8.5 VIBRATIONS

International standards for the balancing quality and vibration values for industrial fans are defined in the standard ISO 14694:2003. The vibrations are measured radially on the shaft bearing of the drive motor. If a measurement is not possible directly on the motor, it is measured radially at the next point that has a mechanical connection to the motor. The following table shows the fan application categories for maximum permissible vibration.

Vibration values according to ISO 14694						
Standard group ISO 14694	Motor power [kW]	Min. balancing quality	Limit values			
			At manufacturer Average values; maximum values in brackets		In operation Average values; maximum values in brackets	
			Fixed mounted [mm/s]	Flexibly mounted [mm/s]	Fixed mounted [mm/s]	Flexibly mounted [mm/s]
BV-2	>0.15<3.7	G16	3.5 (5.1)	5.6 (7.6)	Start-up 5.6 (7.6) Alarm 9.0 (12.2) Slow-down 10 (14)	Start-up 9.0 (12.7) Alarm 14.0 (19.1) Slow-down 16 (21)
BV-3	>=3.7<37	G6.3	2.8 (3.8)	3.5 (5.1)	Start-up 4.5 (6.4) Alarm 7.1 (10.2) Slow-down 9.0 (12.7)	Start-up 6.3 (8.8) Alarm 11.8 (16.5) Slow-down 12.5 (17.8)
BV-4	>=37<300	G2.5	1.8 (2.5)	2.8 (3.8)	Start-up 2.8 (4.1) Alarm 4.5 (6.4) Slow-down 7.1 (10.2)	Start-up 4.5 (6.4) Alarm 7.1 (10.2) Slow-down 11.2 (15.2)

#### 8.6 TIGHTENING TORQUES FOR BOLT CONNETCIIONS

On the basis of VDI 2230 the following tightening torques are recommended for bolts of strength class 8.8:

Nominal diameter [mm]	Tightening torques [Nm]
M4	3,3
M5	6,5
M6	11,3
M8	27,3
M10	54

Nominal diameter [mm]	Tightening torques [Nm]
M12	93
M16	230
M20	464
M24	798

## 8.7 GENERAL HINTS FOR MAINTENANCE

Correct maintenance is decisive for the fan safety of operation and lifetime. Operational disorders due to insufficient or improper maintenance can cause high repair costs and long downtimes.

For this reason, regular maintenance is indispensable.



Before starting maintenance and repair work (especially when the fan must be opened), compliance with the switch-off procedures is essential.

Checks	Interval
The inspection intervals must be shortened at strong degree of pollution, high ambient temperatures and frequent start / many load changes.	
Check, if the fan is installed correctly and safely and pay attention to possible vibrations during operation. If necessary, re-tighten the screw connections.	m
Check the connections of the pipe on the inlet and outlet side, housing cover and shaft seal (if installed) for tightness.	m
Check the electric motor for correct and firm seating and functionality.	MO
Check V-belts	½ y
Check the housing for stress cracks, quiet run and storage temperature. Check the impeller for deformations, wear and cakings.	y
Do all greasing work at the bearings of the fan rotational. Keep attention to the lubricating intervals of the engine manufacturer.	MO

## 8.8 CHECKS

**After completing work, please, check:**

- The completeness of performed work,
- Unless there is reason to complain, the fan can be taken into operation.



After checking and replacing the wear parts, please check, if all safety devices are fully operable.



## 9 TROUBLES / CAUSES / MEASURES

The facts and information relating to „Troubles, cause and measures“ described in this operating manual are formulated in a way that they are understood by persons with a professional training in the fields of:



- electrics / electronics
- mechanics / maintenance

Appropriate tools and test equipment must be made available to this personnel. Before any maintenance and repair work, the fan must be de-energized and protected against re-activation. Unless the specified measures are successful, please, contact the manufacturer.

Trouble	Possible cause	Remedial action
Temperature rise at the bearings	Increased flexing work at bearing by fresh lubrication or new bearing	Fan continue to operate, Temperature normalizes after a certain period by itself
	Lubrication intervals were not observed	Change bearing and correct the lubrication according to the intervals
	V-belt tension too high	Correct V-belt tension
Leakage at the shaft passage	Sealing element worn out	Change sealing element
Unquiet run of fan (heavy vibration)	Foundation is subject to heavy vibration	Damp the foundation / fan
	Impeller unbalance	Balancing required, consult manufacturer
	Deposits on the impeller	Clean the impeller
	Damage on impeller	Consult manufacturer
Motor bearing noise	Motor bearing damaged	Replace bearing or motor, Consult manufacturer or motor supplier
Fan power output too low	Wrong impeller rotating direction	Reverse the rotating direction
	Output reduction facilities are not opened, or opened only partly	Check the output power reduction facilities
	Pipe resistances on inlet or outlet side too high	Reduce resistances, increase the fan power, consult manufacturer
Motor power consumption to high	Defective motor winding	Change motor, consult manufacturer or motor supplier
	Wrong impeller rotating direction	Reverse the rotating direction
	Motor protective switch is not adjusted correctly	Adjust motor protective switch correctly
Motor is switched off by the motor protection switch	Motor protective switch is not adjusted correctly	Adjust motor protective switch correctly
	Motor winding defective	Change motor, consult manufacturer or motor supplier
	Impeller blocked	Check impeller

Trouble	Possible cause	Remedial action
Belt broken or damaged	Normal abrasion	Find reason, change V-belts
	V-belt tension too high	Reduce V-belt pre-tension
	V-belt does not align	Check alignment
V-belts slip through	Wrong pre-tension	Check belt tension and correct if necessary
	Backlash due to decreasing V-belt pre-tension	Check and re-adjust the V-belt
Sliding noises	Motor winding defective	Consult manufacturer
	Impeller unbalance	Balancing required, consult manufacturer
	Foreign body between impeller and housing	Remove the foreign body
Sudden power decrease	Inlet or outlet pipe untight	Check the pipes
	Connecting collar defective	Replace the collar

## 10 EMERGENCY

In case of emergency, switch off the main switch or withdraw the power supply connector.

## 11 DISMANTLING / DISPOSAL

### Dismounting

Dismounting may be done only by qualified personnel. Before starting dismounting work, make sure that the switch-off procedures are followed.



### Disposal

The fan is made mainly of steel and plastics (except the electrical equipment) and must be discarded in compliance with the applicable local environmental regulations.

For discarding the cleaning agents, follow the local regulations and the information given in the manufacturer safety data sheets.

Contaminated cleaning tools (brushes, clothes, etc.) must be discarded in compliance with the manufacturer specifications as well.

Depending on the fan application, the housing and the impeller must be considered as special waste and discarded accordingly.

Injection moulded or sintered housings are provided with recycling signs indicating which type of plastic material was used.

## NOTES